

## TECHNICAL DATA SHEET

# DucoBox Energy Comfort Plus D550 (UK)

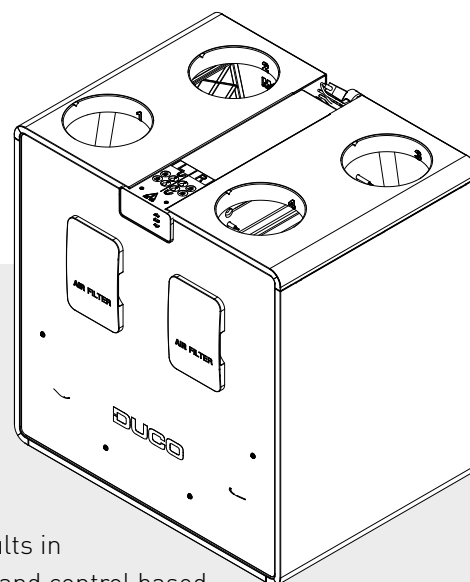

The DucoBox Energy Comfort Plus D550 (UK) is a **balanced ventilation unit with heat recovery**. DucoBox Energy Comfort Plus was developed with the aim of guaranteeing an even quieter operation. Within the DucoBox Energy Comfort range, the left/right exchange is 100% software-driven thanks to the patented principle of the double by-pass.

The demand control of the DucoBox Energy Comfort Plus D550 (UK) results in **intelligent and energy-efficient operation**. Together with the smart demand control based on CO<sub>2</sub> and humidity, the dynamic air distribution filters ensure exceptional efficiency within this compact unit.

The compact and quick-to-install 2-zone valves provide the most energy-efficient result that can be achieved with an MVHR system. Please note that the zone control reduces the noise by **at least 30%**! Comfort rules!

## Versions

Type	Supply and extraction capacity at 150 Pa	Supply and extraction capacity at 200 Pa	2-zone system	Frost protection	Article number
DucoBox Energy Comfort Plus D550 (UK)	550 m <sup>3</sup> /h	550 m <sup>3</sup> /h	yes (external - optional)	imbalance or external heater (optional)	0000-4923

## Physical characteristics

<b>Width x Height x Depth (mm)</b>	760 x 803 x 584
<b>Casing</b>	Coated sheet steel
<b>Colours</b>	White + green
<b>Connections</b>	Inner diameter: Ø 180 mm
<b>Condensate drain</b>	Ø 32 mm (1 ¼") (2x)
<b>Heat exchanger</b>	v1: PP - v2: PET/Alu
<b>Material of inside section</b>	EPP / PP / ABS
<b>Weight</b>	47 kg
<b>Power cable length</b>	2 m (from top of unit)
<b>Mounting</b>	Wall mounting (standard) Floor mounting as an option using a support frame

## Electrical characteristics

<b>Maximum power at 50 Pa</b>	221,1 W
<b>Power supply</b>	230 V, 50 Hz via 3-core power cable with earthed plug
<b>Type of motor</b>	DC
<b>IP class</b>	IP40
<b>Energy conversion efficiency</b>	84.7 % (EN 13141-7)

## Miscellaneous characteristics

<b>Energy class</b>	With 2 sensors (control factor 0.65): A+ Other: A
<b>Filters</b>	Dynamic airflow filter supply air (520 x 190 x 15 mm) Standard: ISO 16890 Coarse 65 % (= G4) Optional: ISO 16890 ePM1 55% (=F7)  Dynamic airflow filter exhaust air (520 x 190 x 15 mm) Standard: ISO 16890 Coarse 65 % (= G4)
<b>Fans</b>	EC fan with backward curved blades
<b>Automatic calibration</b>	Yes (constant pressure)
<b>Installer App</b>	Via Duco Connectivity Board (if permanently mounted) Via Duco Installation Kit (mobile application)
<b>Passive cooling</b>	Automatic passive cooling control via 'NightBoost' function
<b>Operation</b>	Integrated display Use via remote controls and CO <sub>2</sub> or Humidity Sensors Optional via smartphone/tablet (provided Duco Connectivity Board in device)
<b>Sensors</b>	<b>Integrated:</b> pressure, temperature, onboard switch sensor <b>External:</b> CO <sub>2</sub> (via optional Room sensor), Humidity (via optional Room sensor or measurement in ETA duct), external Switch Sensor (voltage-free input) (optional)
<b>Communication</b>	<b>Standard:</b> Duco RF, Duco Wired, Switch Sensor <b>Expandable with Duco Connectivity Board:</b> Modbus TCP (local), REST API (local or via cloud) - both via Ethernet or Wi-Fi

## Pressure/flow characteristics

Flow rate (m <sup>3</sup> /h)	Pressure (Pa)	Absorbed power* (W)
500	300	270
450	300	230
531	250	270
500	250	242
450	250	202
400	250	168
550	200	270
500	200	221
450	200	181
400	200	148
500	150	199
450	150	161

\* The values mentioned are an estimate and cannot be used as substantiation.

## DucoBox Energy Comfort Plus D550

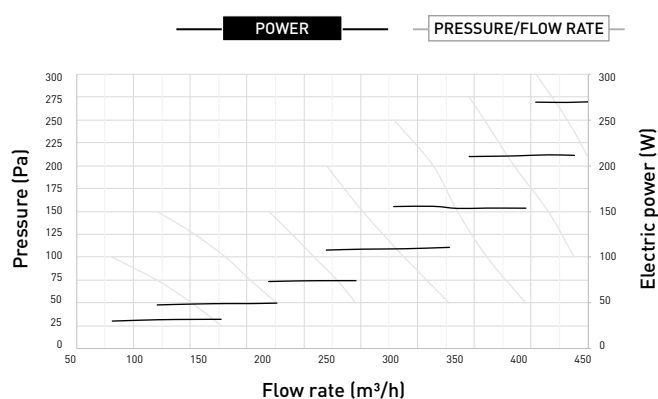

## Systems with rigid ductwork only SAP 2005 results

Exhaust terminal configuration	Specific power of fan (W/l/s)	Heat exchange efficiency (%)
Kitchen + 1 additional wet room	0,74	87
Kitchen + 2 additional wet rooms	0,62	88
Kitchen + 3 additional wet rooms	0,58	88
Kitchen + 4 additional wet rooms	0,60	88
Kitchen + 5 additional wet rooms	0,64	88
Kitchen + 6 additional wet rooms	0,69	88
Kitchen + 7 additional wet rooms	0,78	88

## Systems with rigid ductwork only SAP 2012 results

Exhaust terminal configuration	Specific power of fan (W/l/s)	Heat exchange efficiency (%)
Kitchen + 1 additional wet room	0,66	88
Kitchen + 2 additional wet rooms	0,61	88
Kitchen + 3 additional wet rooms	0,64	88
Kitchen + 4 additional wet rooms	0,71	88
Kitchen + 5 additional wet rooms	0,81	88
Kitchen + 6 additional wet rooms	0,95	87
Kitchen + 7 additional wet rooms	1,11	87

## Sound data

Standards: ISO 5135:2020

Fan Speed	Test mode	Induct Sound Power Levels, dB re. 1pW									
		Octave bands, Hz								LwA	SPL @ 3m
		63	125	250	500	1k	2k	4k	8k		
100%	Supply	80.9	76.3	77.7	79.3	72.7	69.1	65.6	60.3	79.2	61,7
	Extract	76.0	62.7	65.0	61.3	55.1	47.2	42.8	37.8	62.1	44,6
	Breakout	71.2	55.6	60.2	65.2	53.1	49.2	45.4	34.3	62.6	45,1
80%	Supply	79.3	74.1	75.7	77.3	66.9	63.4	59.1	52.2	75.8	58,3
	Extract	75.9	59.6	62.4	55.5	51.3	42.1	36.7	30.4	58.2	40,7
	Breakout	50.4	52.0	57.8	61.8	48.6	44.2	39.5	27.9	58.7	41,2
60%	Supply	73.2	70.2	77.4	67.2	59.4	56.1	50.0	40.8	71.1	53,6
	Extract	64.2	56.6	63.2	48.7	44.0	34.9	29.4	25.5	55.9	38,4
	Breakout	45.8	48.7	58.7	47.3	41.9	37.4	31.0	24.3	52.8	35,3
40%	Supply	69.0	64.4	66.4	59.4	50.0	44.9	36.3	26.0	60.7	43,2
	Extract	60.6	48.9	54.1	41.7	35.7	25.0	25.6	24.6	46.9	29,4
	Breakout	42.4	42.6	53.5	42.0	35.3	26.3	20.5	22.9	45.1	27,6
20%	Supply	60.4	56.4	50.3	42.5	33.6	24.0	18.4	23.1	45.8	28,3
	Extract	51.6	40.7	38.3	26.5	24.5	15.5	17.9	22.6	33.6	16,1
	Breakout	34.2	37.7	38.3	27.5	23.1	16.2	18.0	22.7	31.7	14,2

## Optional accessories

Product	Article number
Siphon flat (Energy)	0000-4376
Duco Connectivity Board	0000-4810
Humidity Sensor (DucoBox Energy Comfort (Plus))	0000-4723
Mounting chair standing (Energy Comfort D400 / Plus)	0000-4740
Filter set 2 x Coarse 65% (Energy Comfort D400 / Plus)	0000-4741
Filter set Coarse 65% / ePM1 55% (Energy Comfort D400 / Plus)	0000-4742
Set Coaxial cable 8m	0000-4418
Pre-Heater DucoBox Energy Comfort (Plus) (UK) 1425W	0000-4825
External Multizone Valves	Miscellaneous

## Dimensions DucoBox Energy Comfort Plus D550 (UK)

Front view

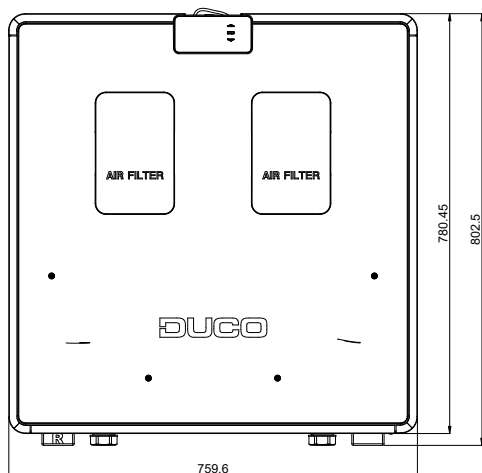

Rear view

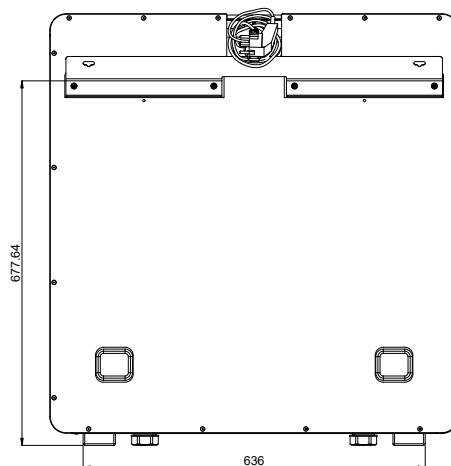

Top view

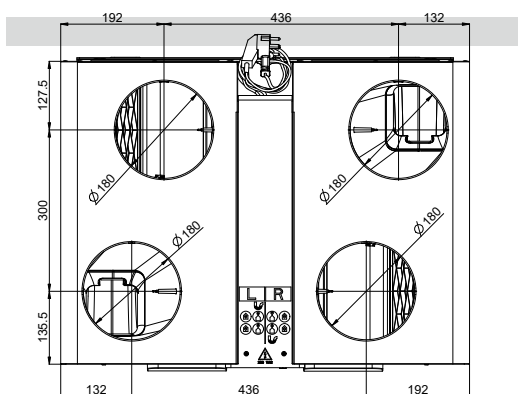

Bottom view

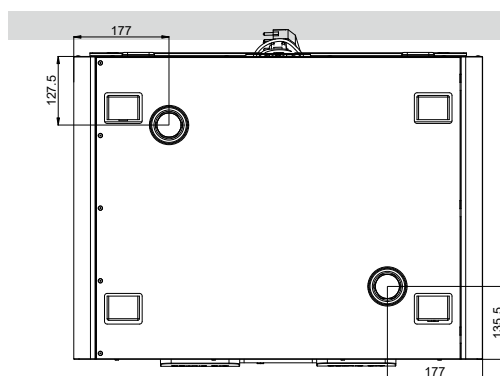

Side view

