

# TECHNICAL DATA SHEET

## DucoBox Energy Comfort D325 (UK)

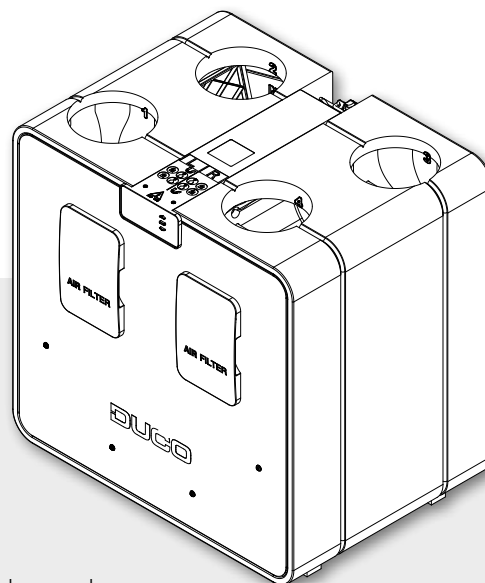

The DucoBox Energy Comfort D325 (UK) is a **mechanical ventilation unit with heat recovery**. It is a compact and lightweight version of the DucoBox Energy Premium. With a capacity of up to 325 m<sup>3</sup>/h, this is the ideal balanced ventilation solution for apartments and serial housing construction.

The demand control of the DucoBox Energy Comfort results in **intelligent and energy-efficient operation**. Together with the smart demand control based on CO<sub>2</sub> and humidity, the dynamic air distribution filters ensure exceptional efficiency within this compact unit.

The left/right exchange is carried out 100% by software thanks to a patented principle of double by-pass.

Moreover, this lightweight unit weighs just 21 kg. In other words: easy **to install by 1 person**. **Automatic calibration** ensures quick and high-quality installation of the unit.

### Versions

Type	Supply and extraction capacity at 150 Pa	Supply and extraction capacity at 200 Pa	2-zone control	Frost protection	Article number
DucoBox Energy Comfort D325 (UK)	325 m <sup>3</sup> /h	292 m <sup>3</sup> /h	yes (external - optional)	imbalance or external heater (optional)	0000-4658

### Physical characteristics

<b>Width x Height x Depth (mm)</b>	700 x 705 x 525 mm
<b>Casing</b>	Coated sheet steel + EPP
<b>Colours</b>	White + black
<b>Connections</b>	Internal diameter: Ø 160 mm
<b>Condensate drain</b>	Ø 32 mm [1 ¼"] [2x]
<b>Heat exchanger</b>	PET / Polystyrene
<b>Material of inside section</b>	EPP / PP / ABS
<b>Weight</b>	21 kg
<b>Power cable length</b>	2 m (from top of unit)
<b>Mounting</b>	Wall mounting (standard) Floor mounting as an option using a support frame

### Electrical characteristics

<b>Maximum power at 50 Pa</b>	96,5 W
<b>Power supply</b>	230 V, 50 Hz via 3-core power cable with earthed plug
<b>Type of motor</b>	DC
<b>IP class</b>	IP40
<b>Energy conversion efficiency</b>	89,0 % (EN 13141-7)

## Miscellaneous characteristics

<b>Energy class</b>	With 2 sensors (control factor 0.65): A+ Other: A
<b>Filters</b>	Dynamic airflow filter supply air (460 x 185 x 15 mm) Standard: ISO 16890 Coarse 65 % (= G4) Optional: ISO 16890 ePM1 55% (= F7)  Dynamic airflow filter exhaust air (460 x 185 x 15 mm) Standard: ISO 16890 Coarse 65 % (= G4)
<b>Fans</b>	EC fan with backward curved blades
<b>Automatic calibration</b>	Yes (constant pressure)
<b>Installer App</b>	Via Duco Connectivity Board (if permanently mounted) Via Duco Installation Kit (mobile application)
<b>Passive cooling</b>	Automatic passive cooling control via 'NightBoost' function
<b>Operation</b>	Integrated display Use via remote controls and CO <sub>2</sub> or Humidity Sensors Optional via smartphone/tablet (provided Duco Connectivity Board in device)
<b>Sensors</b>	<b>Integrated:</b> pressure, temperature, onboard switch sensor <b>External:</b> CO <sub>2</sub> (via optional Room sensor), Humidity (via optional Room sensor or measurement in ETA duct), external Switch Sensor (voltage-free input) (optional)
<b>Communication</b>	<b>Standard:</b> Duco RF, Duco Wired, Switch Sensor <b>Expandable with Duco Connectivity Board:</b> Modbus TCP (local), REST API (local or via cloud) - both via Ethernet or Wi-Fi

## Pressure/flow characteristics

Flow rate (m <sup>3</sup> /h)	Pressure (Pa)	Absorbed power* (W)
253	250	117
200	250	91
292	200	119
250	200	92
200	200	72
150	200	55
325	150	120
250	200	82
200	150	63
150	150	49
200	100	49
150	100	35

\* The values mentioned are an estimate and cannot be used as substantiation.

## DucoBox Energy Comfort D325

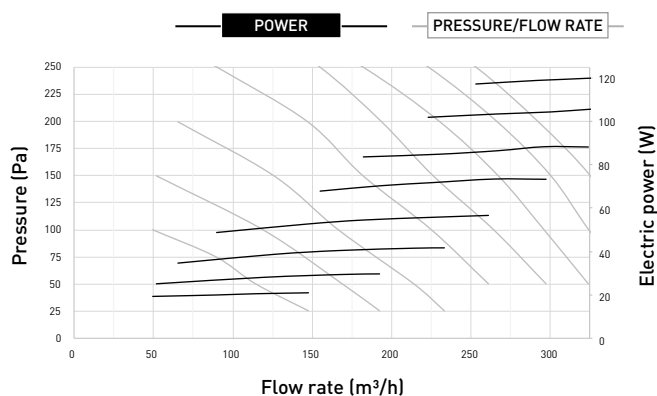

## Systems with rigid ductwork only SAP 2005 results

Exhaust terminal configuration	Specific power of fan (W/l/s)	Heat exchange efficiency (%)
Kitchen + 1 additional wet room	0,66	91
Kitchen + 2 additional wet rooms	0,57	91
Kitchen + 3 additional wet rooms	0,55	91
Kitchen + 4 additional wet rooms	0,57	91
Kitchen + 5 additional wet rooms	0,62	91
Kitchen + 6 additional wet rooms	0,69	90
Kitchen + 7 additional wet rooms	0,79	90

## Systems with rigid ductwork only SAP 2012 results

Exhaust terminal configuration	Specific power of fan (W/l/s)	Heat exchange efficiency (%)
Kitchen + 1 additional wet room	0,60	91
Kitchen + 2 additional wet rooms	0,57	91
Kitchen + 3 additional wet rooms	0,61	91
Kitchen + 4 additional wet rooms	0,71	90
Kitchen + 5 additional wet rooms	0,81	90
Kitchen + 6 additional wet rooms	0,98	89
Kitchen + 7 additional wet rooms	1,17	89

## Sound data

Standards: ISO 5135:2020

Fan Speed	Test mode	Induct Sound Power Levels, dB re. 1pW									
		Octave bands, Hz								LwA	SPL @ 3m
		63	125	250	500	1k	2k	4k	8k		
100%	Supply	78.1	69.9	71.9	64.9	57.9	57.4	51.6	48.3	67.6	50.1
	Extract	67.0	61.5	62.9	52.5	46.4	40.7	32.9	26.8	56.8	39.3
	Breakout	54.0	49.6	60.6	58.4	55.6	53.6	48.1	37.4	61.1	43.6
80%	Supply	73.8	66.8	67.2	59.8	53.1	52.1	45.9	41.8	62.6	44.7
	Extract	62.3	56.4	58.6	46.7	42.1	36.0	27.9	26.1	52	34.5
	Breakout	44.2	45.6	57.4	54.0	52.1	49.2	43.3	31.5	57	39.5
60%	Supply	66.9	61.6	59.2	54.1	46.9	45.1	37.7	31.3	55.8	38.3
	Extract	59.3	52.4	49.6	40.8	36.3	29.1	22.1	24.1	44.8	27.3
	Breakout	39.6	41.5	49.7	48.4	46.8	42.0	35.6	25.6	50.6	40.1
40%	Supply	59.0	55.8	50.2	47.0	39.6	34.5	24.7	24.8	48.1	30.6
	Extract	53.4	45.4	42.0	33.5	29.2	21.7	19.2	24.3	38	20.5
	Breakout	35.6	34.5	42.6	41.2	41.4	32.3	23.2	24.2	43.9	26.4
20%	Supply	57.1	43.3	38.9	36.2	27.1	21.0	19.1	24.2	38.2	20.7
	Extract	52.6	40.4	34.2	25.0	22.6	17.8	18.9	24.3	32.7	15.2
	Breakout	32.8	29.5	36.0	35.1	36.6	22.1	19.3	24.3	38.3	20.8

## Optional accessories

Product	Article number
Siphon flat (Energy)	0000-4376
Duco Connectivity Board	0000-4810
Humidity Sensor (DucoBox Energy Comfort (Plus))	0000-4723
Mounting chair standing (Energy Comfort D325)	0000-4546
Filter set 2 x Coarse 65 % (Energy Comfort D225/325)	0000-4547
Filter set Coarse 65 % / ePM1 55 % (Energy Comfort D225/325)	0000-4661
Set Coaxial cable 8m	0000-4418
Pre-Heater DucoBox Energy Comfort (Plus) (UK)1425W	0000-4825
External Multizone Valves	Miscellaneous

## Dimensions of DucoBox Energy Comfort D325 (UK)

Front view

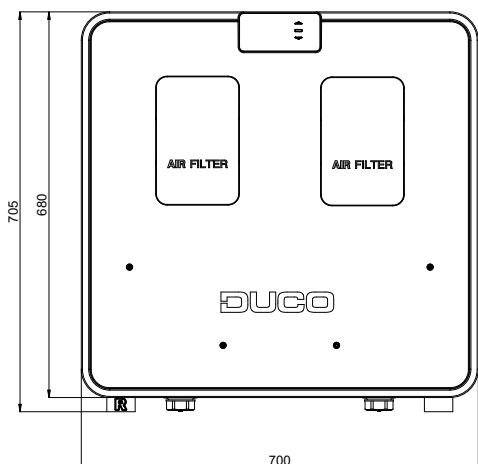

Rear view

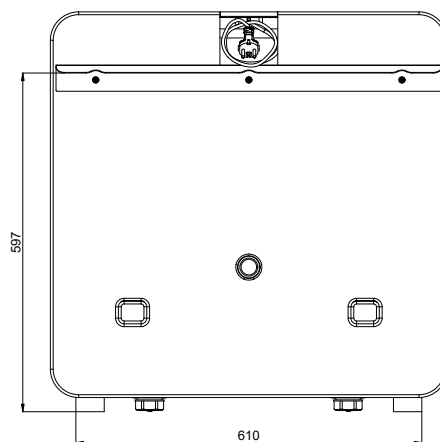

Top view

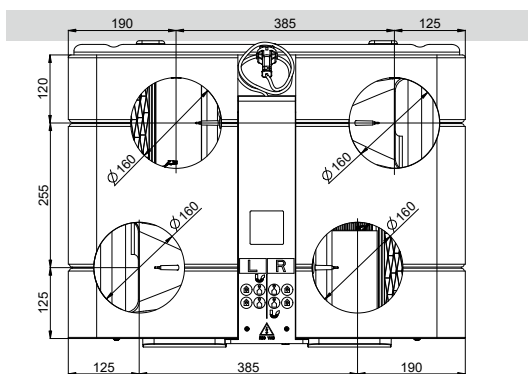

Bottom view

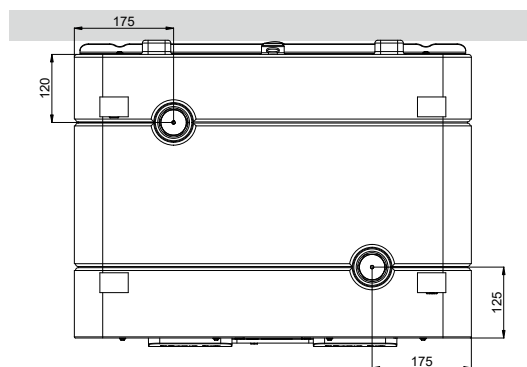

Side view

