

TECHNICAL DATA SHEET

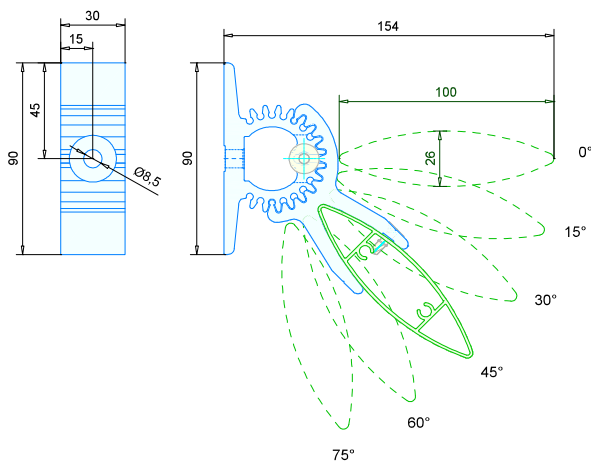

TYPE	DucoSun Ellips 100 - MULTIFIT
DESCRIPTION	External permanent solar shading system with fixed blades
SHAPE OF BLADE	Blade with elliptical cross-section
DIMENSIONS	100 mm x 26 mm
MATERIAL	Aluminium : EN AW-6063 T66 (EN 573-3) Profile thickness : min. 1,5 mm
ANGLE OF BLADE	0° / 15° / 30° / 45° / 60° / 75°
PITCH OF BLADE (S)	To be determined according to project
MAX. SPAN	2800 mm @ 800Pa
COVERPLATES	Aluminium lasered coverplates - thickness 3 mm (AlMgSi0,5)
MULTIFIT	Aluminium extruded bracket - width 30 mm (EN AW6063-T66 (F25))
FIXATION BLADE	Self-drilling countersunk screw 4.8x16 DIN7504-O (AISI 304)
FIXATION COVERPLATE	Self-tapping countersunk bolt M6x30 DIN7500-MZ (AISI 304)
FIXATION MULTIFIT	On Duco mullion or directly against the underlying structure. (Ø8,5)
REACTION TO FIRE	A2-s1,d0 (EN13501-1)
SURFACE TREATMENT	- Standard aluminium anodised (15-20µm) according Qualanod - Polyester powder coated (60-80µm) according Qualicoat Seaside type A



3

2

1

D

D

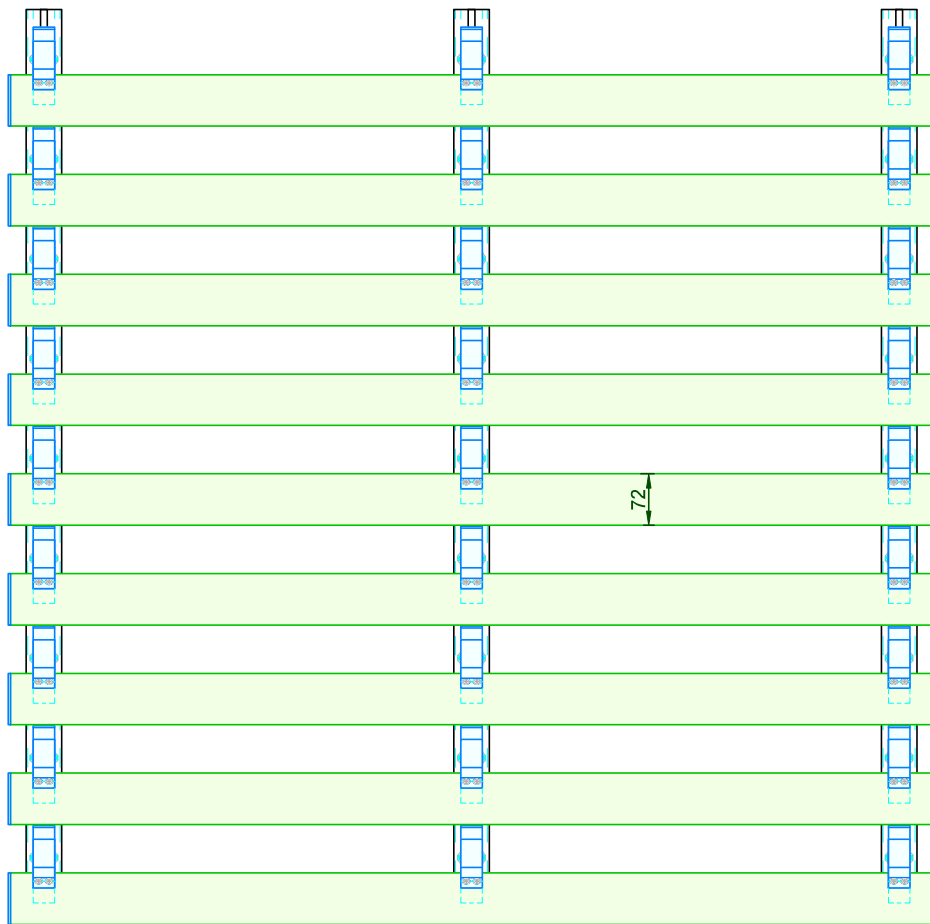

C

C

72

B

B

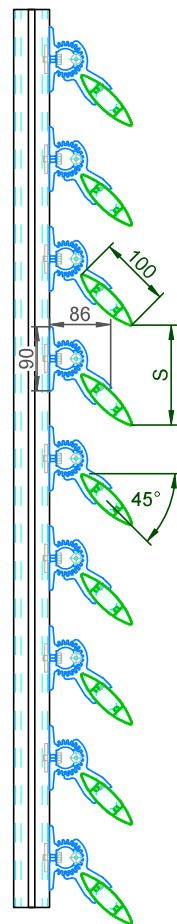
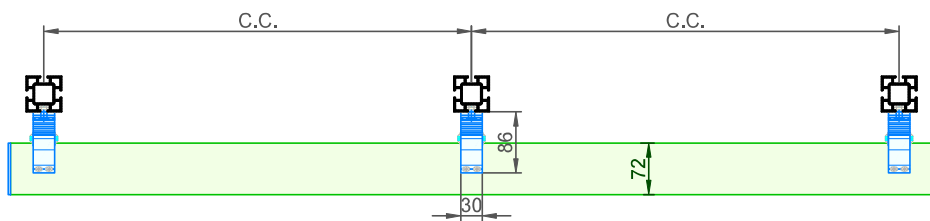

A

A

DucoSun **Ellips 100** Multifit - 45°

Date : 28/06/2024

Scale: 1/7,5

DUCO
Ventilation & Sun Control

Bedrijvenlaan 2 - 8630 VEURNE
tel. 0032-58/330066 - fax.0032-58/330067
email: info@duco.eu www.duco.eu

This drawing is the property of Duco Projects NV and cannot be copied or shown to a third party without prior written authorisation from Duco Projects NV.

Tol. : ISO 2768-mK

Draftsman: JHX

Mat. :

Ref nr. :

Format : A3



outline:

weight:

coat. surf:

Drawing nr. :

TF_Ellips 100_MF

mm

kg/m

dm²/m

3

2

1