

TECHNICAL DATA SHEET



TYPE	DucoSun 150CF Vertical															
DESCRIPTION	External permanent solar shading system															
SHAPE OF BLADE	150CF															
PITCH	190 mm															
BLADE HEIGHT	117,4 mm															
BLADE DEPTH	105 mm															
BLADE ANGLE	45°															
INSTALLATION DEPTH	<table border="0"> <tr> <td>with mullion 50/125</td> <td>236 mm</td> </tr> <tr> <td>with mullion 50/50</td> <td>183 mm</td> </tr> <tr> <td>with mullion 30/50</td> <td>174 mm</td> </tr> <tr> <td>with mullion 50/50</td> <td>161 mm</td> </tr> <tr> <td>with mullion 30/50</td> <td>161 mm</td> </tr> <tr> <td>with mullion 21/50 MULTI</td> <td>161 mm</td> </tr> <tr> <td>with mullion 50/12</td> <td>123 mm</td> </tr> </table>		with mullion 50/125	236 mm	with mullion 50/50	183 mm	with mullion 30/50	174 mm	with mullion 50/50	161 mm	with mullion 30/50	161 mm	with mullion 21/50 MULTI	161 mm	with mullion 50/12	123 mm
with mullion 50/125	236 mm															
with mullion 50/50	183 mm															
with mullion 30/50	174 mm															
with mullion 50/50	161 mm															
with mullion 30/50	161 mm															
with mullion 21/50 MULTI	161 mm															
with mullion 50/12	123 mm															
MAX. BLADE LENGTH	6000 mm															
MAX. SPAN	2515 mm @ 800Pa															
MATERIAL	<table border="0"> <tr> <td>Aluminium :</td> <td>EN AW-6063 T66 (EN 573-3)</td> </tr> <tr> <td></td> <td>Profile thickness : min. 1,3mm</td> </tr> <tr> <td>Thermoplastic parts :</td> <td>Clips</td> </tr> <tr> <td></td> <td>Polyamide PA 6,6 -reinforced with glass fibre</td> </tr> </table>		Aluminium :	EN AW-6063 T66 (EN 573-3)		Profile thickness : min. 1,3mm	Thermoplastic parts :	Clips		Polyamide PA 6,6 -reinforced with glass fibre						
Aluminium :	EN AW-6063 T66 (EN 573-3)															
	Profile thickness : min. 1,3mm															
Thermoplastic parts :	Clips															
	Polyamide PA 6,6 -reinforced with glass fibre															
SURFACE TREATMENT	<ul style="list-style-type: none"> - standard aluminium anodised (15-20µm) according Qualanod - polyester powder coated (60-80µm) according Qualicoat Seaside type A - specific RAL codes and/or textured paint on request 															
OPTIONS	- endpiece (plastic)															

3

2

1

D

D

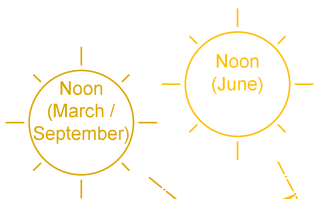

C

C

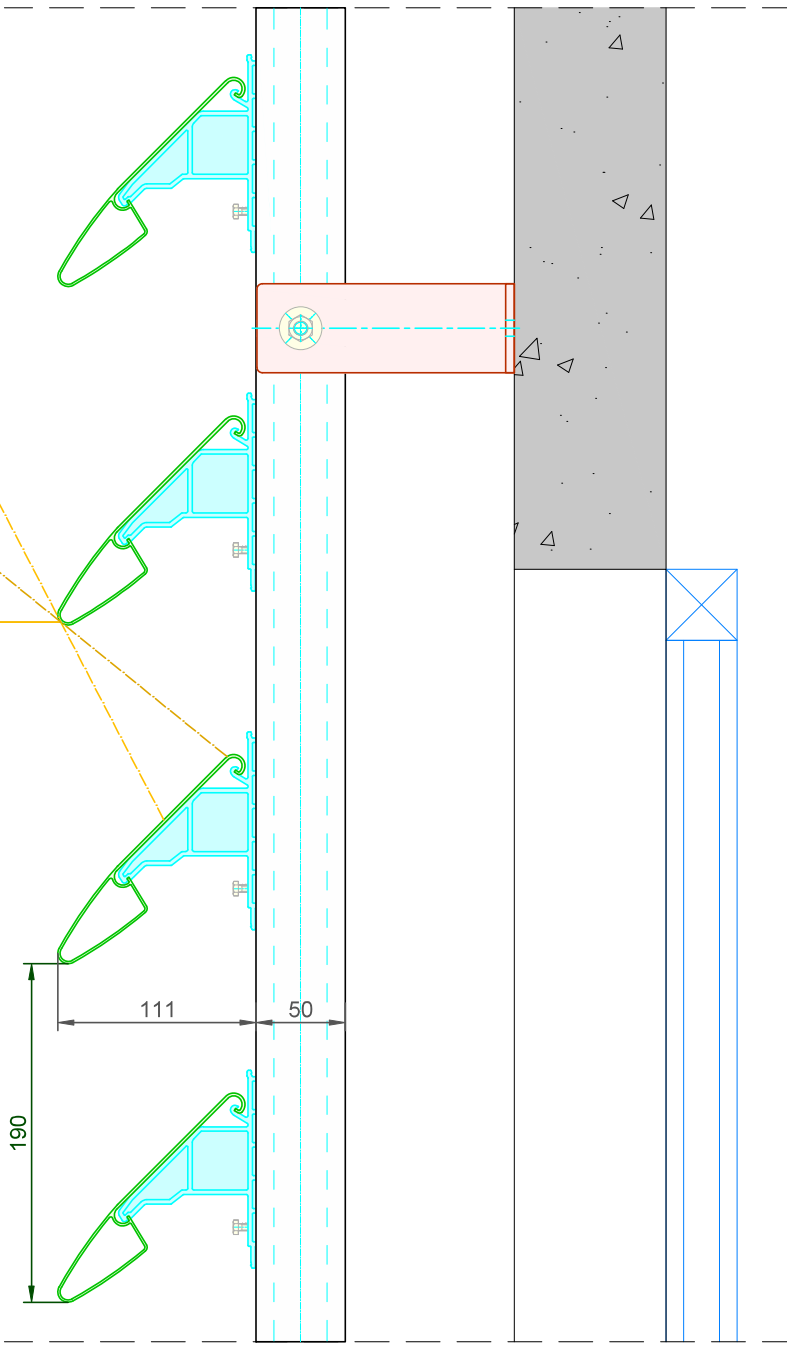

B

B

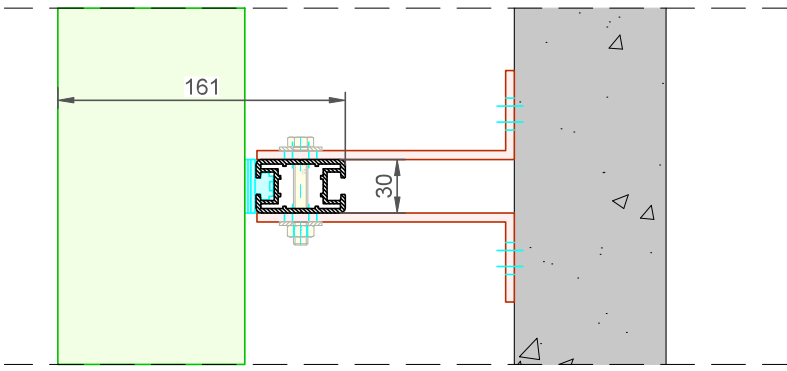

A

A

DucoSun Vertical Blade 150CF Mullion 30/50			Date : 12/09/2024
			Scale: 1:3
DUCO		Tol. : ISO 2768-mK	Draftsman: SVE
Ventilation & Sun Control		Mat. :	Ref nr. :
Bedrijvenlaan 2, - 8630 VEURNE tel. 0032-58/330066 - fax.0032-58/330067 email: info@duco.eu www.duco.eu		Format : A3	
This drawing is the property of Duco Projects NV and cannot be copied or shown to a third party without prior written authorisation from Duco Projects NV.		outline: mm	
		coat. surf: dm ² /m	DucoSun Verticaal - C&D - 150CF DP 30-50

3

2

1